



---

University of Bologna

**Department of Electrical Engineering**

PhD in Electrical Engineering  
XIV course

**CONTROL TECHNIQUES FOR MATRIX  
CONVERTER ADJUSTABLE SPEED  
DRIVES**

PhD Thesis of  
**MARCO MATTEINI**

Tutor  
**Prof. DOMENICO CASADEI**

PhD Coordinator  
**Prof. FRANCESCO NEGRINI**

---

1998-2001

# Chapter 1

## Introduction

---

This chapter gives to the reader a brief overview on the static AC/AC power frequency conversion structures and introduces the matrix converter, which is the topic of this thesis. The matrix converter is a flexible power converter whose employment has been proposed in many different applications. The focus of this thesis will be upon the application of the matrix converter to induction motor drives or AC drives.

Fistly proposed in 1976, the interest in matrix converter has steadily growth, pushed by the progress of the power electronics device technology and the prospect of realising a very compact and reliable all-silicon AC/AC converter. The historical path of the matrix converter technology is shortly covered, pointing out what the main issues are.

Finally, the reasons and the aims of the research work that has led to the present thesis as well as the structure of the thesis are explained.

### 1.1 Static AC/AC Power Frequency Conversion

In general, the conversion of an input ac power at a given frequency to an output power at a different frequency can be obtained with different systems, employing rotating electrical machinery, nonlinear magnetic devices or static circuits containing controllable power electronic switches [1]. Restricting the analysis of AC/AC power frequency conversion to static circuits, the available structures can be divided in “direct” and “indirect” power conversion schemes.

Indirect schemes consists of two or more stages of conversion and an intermediate DC-link stage is always present. A typical example of two stage indirect AC/DC/AC power frequency conversion is the diode-bridge rectifier-inverter structure, in which an AC power is firstly converted to a DC power (diode rectifier), and then converted back to an AC power at variable frequency (inverter). In direct conversion schemes a single stage carries out the AC/AC power frequency conversion.

#### 1.1.1 Indirect AC/AC Power Frequency Converter

In Fig. 1 two indirect schemes are shown. The scheme shown in Fig.1.1.(a) represents the well-known Diode-Bridge Voltage Source Inverter (DB-VSI) topology that is today the preferred solution in AC drive technology, especially in the low- and medium-power range.

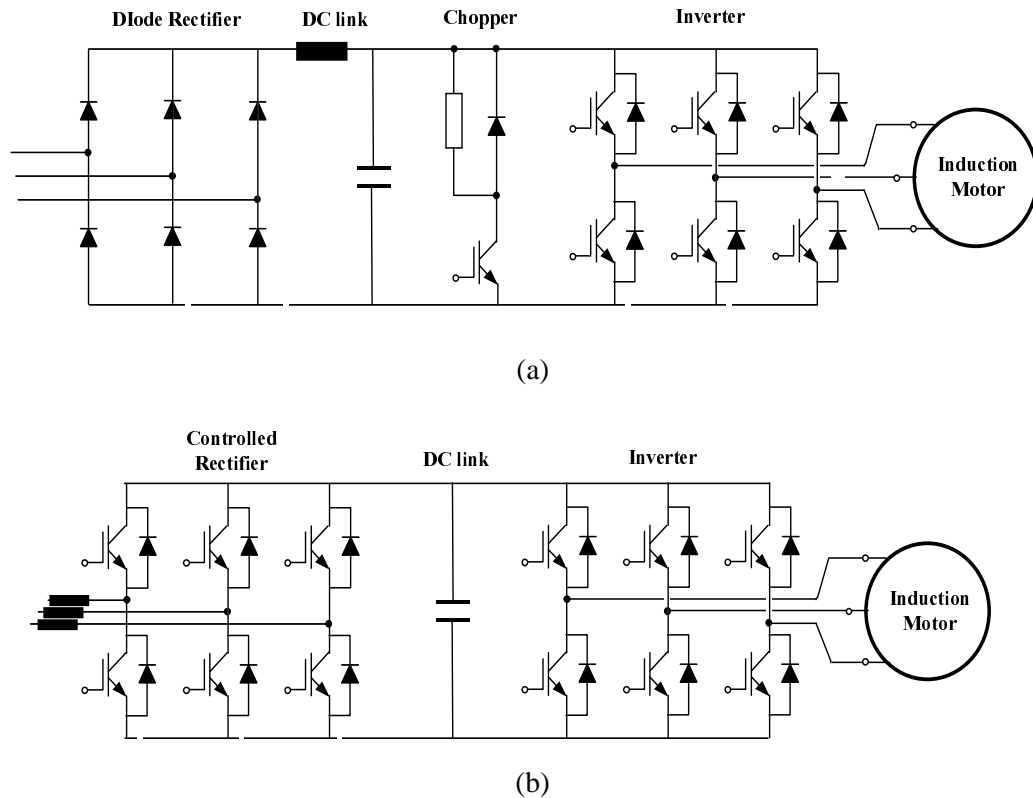

Fig.1.1. AC/AC indirect power frequency converter, with intermediate DC-link stage.  
a) Diode rectifier-PWM VSI converter. b) PWM rectifier-PWM VSI converter.

The diode-bridge converts the electrical power from AC to DC, realizing along with the DC-link filter the rectification stage, while the voltage source inverter converts DC back to AC with variable amplitude and frequency voltages, carrying out what is usually named inversion stage.

This is a very popular and consolidated conversion scheme. It is a reliable solution with low production costs, simple to implement and with high performance modulation strategies available (Pulse Width Modulation, Space Vector Modulation, etc.). But it has also some drawbacks. The input AC currents drawn by the diode-bridge rectifier contain a large amount of harmonics that produces distortion of the input line voltages, having a negative impact on the performance of sensitive loads and equipments connected to the same supply. These current harmonics cause additional harmonic losses on the utility system and may excite electrical resonance, leading to large overvoltages. The greater use of this type of power electronics converter scheme that has been experienced in the last years have raised the problem of the utility power quality and serious concern.

As the current direction in a diode rectifier cannot reverse, some mechanism must be implemented to handle an eventual energy flow reversal, as during an electromagnetic braking of the motor, in order to avoid that the DC-bus voltage can reach destructive levels. In the DB-VSI conversion scheme such mechanisms are always dissipative ones and hence they can be effectively employed only when the energy to dissipate is low [2].

The DC-link capacitor represents another weak point of the indirect conversion scheme, particularly for those using electrolytic capacitors. These capacitors have a high energy storage capability but also a high temperature sensitivity which reduces their lifetime, as shown in Fig.1.2, determining higher maintenance costs of the conversion system. It should be noted that the electrolytic capacitor have by far the shortest lifetime of any element, active or passive, used in power electronic converters [2].

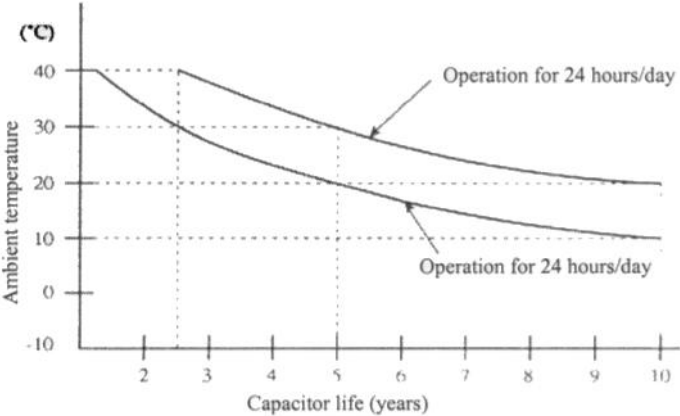

Fig.1.2. Capacitor life-time expectation depending on the ambient temperature in a low-power industrial diode-bridge VSI (reprinted from [41], pp. A-19, Appendix 5)

The topology of the indirect conversion scheme (b), shown in Fig.1.1, differs from (a) for the rectification stage, where the diode-bridge rectifier is replaced by PWM-controlled rectifier. This solution makes possible for the conversion system a bidirectional power flow from the main to the motor, which might become attractive for those medium and high power range applications in which regenerative operations and speed reversals are involved in steady state operating conditions, as in hoisting applications like elevators and cranes. Moreover, a PWM-controlled rectifier allows for a strong reduction of the input currents harmonic distortion content, due to the high switching frequency of the rectifier, and a consequent reduction of the filtering components required.

But there are also some disadvantages. The cost is higher, due to a higher number of power semiconductor devices, the combined control of the PWM-controlled rectifier and inverter is quite complicated. In addition, the reliability problem related to the reduced lifetime of the DC-link capacitor holds. For these reasons, the indirect conversion scheme (b) of Fig. 1.1. is still scarcely employed.

### 1.1.2 Direct AC/AC Power Frequency Converter.

Direct static AC/AC power frequency converters basically consist of an array of static power switches connected directly between the input and output terminals. The basic operating principle is to piece together an output voltage waveform with the desired fundamental component from selected segments of the input voltage waveforms. The most-known example of this type of power frequency converter probably is the classical cycloconverter, proposed in the early 1930s [1]. Although the family of direct power frequency converters does not include just the cycloconverters, the following analysis will be limited to only these type of direct frequency converters.

There are two type of cycloconverters: the naturally commutated cycloconverter (NCC) and the forced commutated cycloconverter (FCC).

In NCC the switches are naturally turned-off by the voltages of the AC supply. Also for these reasons thyristors are commonly used as switches. As a consequence of such operating mode, in NCC the maximum output frequency is limited to a value that is only a fraction, one-third or one-half, of the source frequency. This upper output frequency limit is a serious constraint in AC motor drive applications, which can be overcome only when the AC power supply for the cycloconverter is generated by an engine-driven high frequency generator [3].

In FCC the turn-off of the switches is independent of the source and load voltages allowing by proper switching techniques the output frequency to be higher than the input frequency. For FCC thyristors are not the best-suited switches as they do not have self-turn off-capability; auxiliary commutating circuits and components should be added.

A cycloconverter can be viewed as made up of a number of phase-controlled converter circuits connected to an AC supply system. Each converter circuit is controlled so that a different-frequency output voltage waveform is generated from segments of the same polyphase input voltages. In Fig. 1.3 a three-phase to three-phase cycloconverter consisting of three-phase, half wave, phase-controlled converters is shown.

In NCC the control of the output voltage and frequency is carried out by a proper modulation of the thyristors firing angle  $\alpha$ . For given input supply voltages and number of input phases, the thyristors' firing angle  $\alpha$  represents the unique control variable of converters output [3]. In Fig. 1.4 it is shown the voltage and current waveforms for one of the positive group converter of the phase-controlled cycloconverter in Fig. 1.3. as result of a proper modulation of the thyristors firing angle.

For a naturally commutated cycloconverter the theoretical maximum input/output voltage transfer ratio  $r_{max}$  is given by

$$\frac{V_{omax}}{V_{imax}} = r_{max} = \frac{m}{\pi} \sin\left(\frac{\pi}{m}\right)$$

where  $m$  is the number of the input phases. In the case of three input phases  $r_{max} \cong 0.827$  [1, pp. 73].

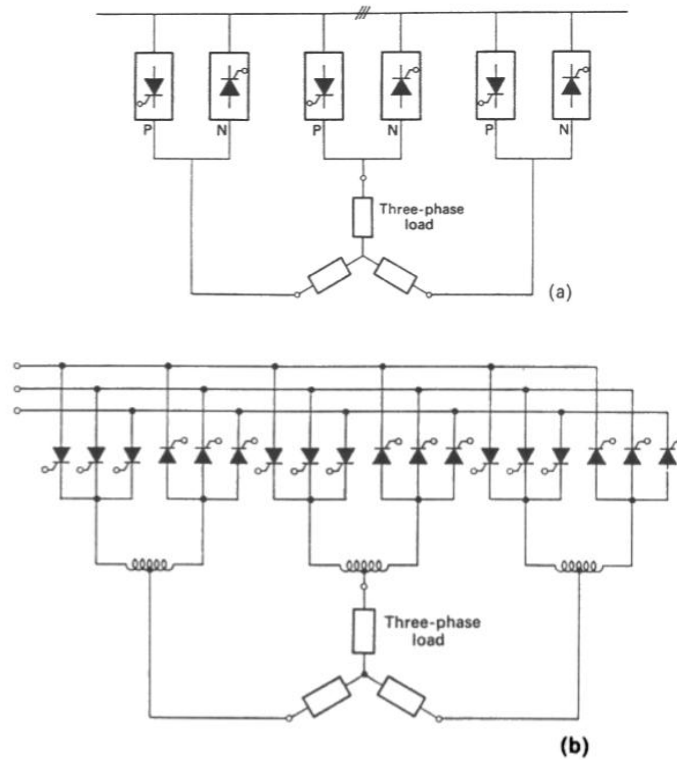

Fig.1.3. Three-phase to three-phase half wave cycloconverter: (a) schematic diagram; (b) basic circuit (reprinted from [3], pp. 203, Fig.5.5).

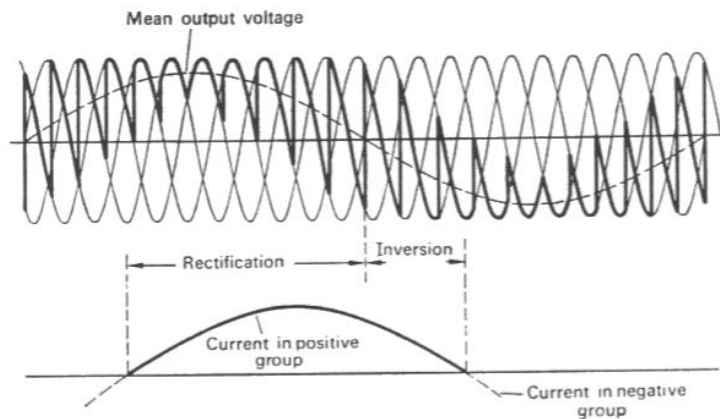

Fig. 1.4. Voltage and current waveforms for the positive group of a phase-controlled cycloconverter when feeding an inductive load at 0.6 power factor (reprinted from [3], pp. 201, Fig.5.3).

Since based on a phase-controlled operating mode, the cycloconverter draws from and feed to the AC supply nonsinusoidal currents. Moreover, due to the direct connection between the input and output phases, when a reactive load has to be fed by the AC supply through a cycloconverter, a reactive power transfer must take place through the cycloconverter itself. As a

consequence, power factor, fundamental input displacement angle and harmonic distortion have to be considered as functional characteristics of the converter; this holds for all the direct power frequency converters.

In NCC the input current always lags the supply voltage, because phase delay is always present, irrespective of the nature of the load. This means that the fundamental input displacement factor can be never at unity, as it is shown in Fig. 1.5. The harmonic distortion factor of input currents is also significant.

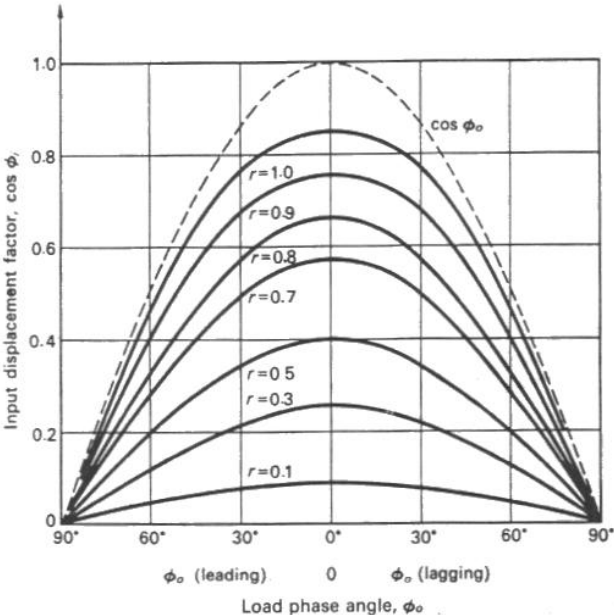

Fig. 1.5. Variation of the input displacement factor for a phase-controlled cycloconverter (reprinted from [3], pp. 207, Fig.5.7).

Making a comparison with indirect DC-link converter, the naturally commutated cycloconverter has the advantages of having lower commutation and conduction losses, allowing for a more compact power circuit design, and of having inherent bidirectional power flow capability. But it has also some relevant disadvantages, as the low output frequency upper limit, the lower input/output voltage transfer ratio, the large number of thyristors which requires complex control circuitry, and last, but not least, the poor input power factor. Because of these features, the major applications of naturally commutated cycloconverters have been restricted to low-speed, high power reversible AC drives.

Many of the above NCC limitations can be overcome with forced-commutated cycloconverter. By introducing semiconductor devices with self-turn-off capability it becomes possible to implement more sophisticated control algorithms that using high switching frequency allow the output frequency to be higher than the input frequency, the input power factor and the input/output voltage transfer ratio to be improved.

## 1.2 The Matrix Converters: State of the Art

The matrix converter is nothing but a three-phase to three-phase forced commutated cycloconverter. It consists of nine bidirectional switches that connect each output phase to each input phase, as it is shown in Fig.1.6.

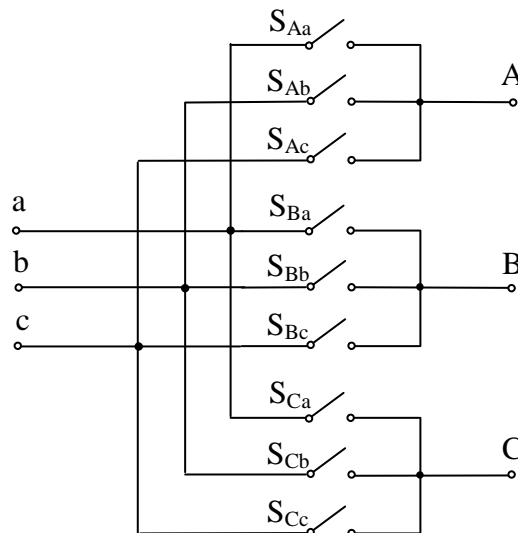

Fig. 1.6. Schematic circuit of a three-phase to three-phase matrix converter.

The matrix converter topology was originally presented in 1976 by Gyugyi-Pelly [1] but it was in 1980 that the basic configuration and control of three-phase matrix converter were introduced by Venturini in [4] and [5]. These papers, along with the progress of the power semiconductor devices technology experienced at that time, boosted a renewed interest in direct AC/AC power frequency converter, as an elegant silicon-intensive and efficient way to convert electric power for motor drives, uninterruptible power-supply, variable frequency generators, and reactive energy control [6]. Since then, many different names have been used in literature to define this converter topology: Unrestricted Frequency Changer and Direct Frequency Changer [1], Generalized Transformer [4], Forced-Commutated Cycloconverter [7]-[9], Matrix Converter [10]-[13], Direct AC/AC Converter [6], Forced-Commutated Direct Frequency Changer [14], Direct Frequency Changer [15] and Venturini Converter [16]. In the last years the name Matrix Converter has established itself as the commonly used in literature and it is also used throughout this thesis.

At the time the matrix converter was originally presented as unrestricted frequency changer in [1], although it provided better performance compared to naturally commutated cycloconverters, it still had significant output voltage limitations and serious waveforms distortion.

In 1980 Venturini proposed in [3] an alternative high switching frequency control algorithm which was more effective than traditional control techniques but still had an output



voltage limitation equal to half of the input voltage and restriction in the input power factor control. During the 1980s other approaches conceptually based on the classical rectifier-inverter control methods were proposed [7],[10],[17],[18]. These works yielded an improvement in the maximum output voltage capability and waveforms of the matrix converter but did not reach the full utilization of the matrix converter potential. At the end of the 1980s Venturini proposed an improved control strategy [19] that raised the maximum input-output voltage transfer ratio to 0.866, which was demonstrated to be the theoretical upper limit under the constraint of sinusoidal input and output waveforms.

In the late 1980s and early 1990s space vector modulation schemes were also introduced by several authors [9],[13],[15]. The space vector modulation of matrix converter allows to obtain the full theoretical input-output voltage transfer ratio, sinusoidal input current and output voltage waveforms and to control the converter input power factor [11],[ 13].

Despite of such academic research activity the matrix converter did not succeed to attract the AC drive industry interest, basically because of a number of practical implementation problems related to the bidirectional switch realization and commutation, the protection strategy but also to the inherent voltage transfer ratio limitation. Till the early of the 1990s very few prototypes of matrix converter were built.

Since then, the focus of the academia activity, which had mainly dealt with modulation and control algorithms, started to concentrate also on implementation and hardware problems related to the matrix converter technology [20]–[29]. The results yielded by this research work, along with the continuous development of power electronic devices and integration, and the increasing pressure of the AC drives market for higher reliability and cost reduction, convinced the AC drive industry to invest in the matrix converter technology and today we are close to see the breakthrough of matrix converter in the market of AC drives [28]-[31].

### **1.3 Reasons, Aims and Structure of the Thesis**

If someone looks at the development and progress of power electronics technology since the advent of power semiconductor devices in the 1950's, he might be astonished by seeing how many inventions of devices, converter circuits, controls and applications have enriched this technology [32],[33]. During the last three decades the use of power electronics has been growing extensively in industrial, commercial, residential and aerospace environments for various applications as heating and lighting control, AC and DC power supplies, electrochemical processes, machine drives, electrical welding and harmonic filtering just for mentioning some of them. Looking at the future, power electronics is expected to have an increasing influence on a nation's industrial productivity and energy consumption.

Inside the power electronics galaxy, the Adjustable Speed Drive (ASD) technology has a relevant role. The World market for adjustable speed drives is still growing rapidly, at a rate of approximately 10% per year, driven in part by a gradually growing base of installed polyphase AC motors and more rapidly by increasing penetration of variable speed control into this industrial motor base [34]. Nevertheless adjustable speed drives technology is not at the maturity, but it is still an emerging technology, pushed by internal drivers as the evolution of power electronic components and microprocessors, as well as external market drivers like quality, reliability and efficiency, price, global standards, performance and features, size and packaging, system integration, and product flexibility [34],[35].

At the time of this PhD work starting the matrix converter represented, and it still does, a challenge to many of these market requirements since for many features the matrix converter is a more attractive solution for adjustable speed drives than the standard ones. Moreover, the matrix converter has the fascination of a “planet” not completely known yet, where there might be still a lot of things to discover and to understand.

The all above was the reason to accept the proposal of my supervisor to work on the matrix converter technology, and after three years of hard work carried out the conclusion is that my expectations have not been betrayed.

The bulk of the scientific work carried out on matrix converters is basically concentrated on the converter control strategies and on the bi-directional switches commutation issue.

With regard to the first topic, three control strategies based on the Space Vector Modulation (SVM) technique have been analysed and compared under ideal and non ideal supply voltage conditions. In general the control strategies are derived under the assumption that input voltages are ideal, that are sinusoidal and balanced; but in practice the supply is usually unbalanced to a certain extent and distorted, due to the presence of non-linear loads connected to the grid. Taking into account that the matrix converter is, because of the absence of internal energy storage components, sensitive to disturbances in the input voltages, it is mandatory for an effective control strategy to be able to compensate such disturbances and it becomes of practical interest to investigate the performance of different control strategies under non ideal supply voltages. The three strategies performance have been experimentally verified on a 7 kVA matrix converter prototype.

A fourth control strategy, based on the Direct Torque Control (DTC) scheme of induction motor has been also analysed. The performance of the control scheme has been previously tested by numerical simulations and then experimentally verified. A modified control strategy which allows to reduce the input current harmonic distortion is also proposed.

As far as the bi-directional switches commutation problem is concerned it is tightly related to the lack of a true forced-commutated bi-directional switch. The commutation issue has been considered in the past as one of the main obstacle to the industrial development of the matrix converter. A thorough survey of the today available commutation strategies is given and a new

commutation strategy is proposed. The proposed strategy relies on both output currents and input voltages sensing and it allows to safely commute within three steps. A description of the design and implementation of this strategy on a Complex Programmable Logic Device (CPLD) is also presented.

With regard to the structure of this thesis, it consists of 5 chapters. Each chapter terminates with a list of references used in the chapter. Introduction is given in each chapter and conclusions are drawn for chapters 3,4, and 5 and a final conclusion ends the thesis.

Chapter 2 gives a general description of the fundamentals of matrix converters. The topology is presented and the possible configurations which allow to implement a bi-directional switch are discussed. A qualitative analysis of the matrix converter performance is carried out; advantages and disadvantages are emphasized. The chapter also presents an overview of the complete matrix converter drive, paying attention to some implementation aspects which are still somehow outstanding matters like the input filter and the protection strategy of the converter.

Chapter 3 copes with the basic issue of the bi-directional switches commutation. The possible different implementations of the bi-directional switch are reviewed . The today available commutation strategies, based on either the input voltages or output currents measurement, are presented and discussed. A new 3-Step commutation strategy, which relies on both voltage and current sensing, is proposed and a brief description of its implementation on a Complex Programmable Logic Device (CPLD) is given.

Chapter 4 focuses on the modulation and control of the three-phase matrix converter. A brief review of the different control strategies proposed in literature is given. Then, three modulation strategies based on the Space Vector modulation (SVM) technique are considered. The performance of these strategies under ideal and non-ideal supply voltage conditions are analysed in details and compared. The results of the theoretical analysis and experimental tests carried out, were presented in two papers [35],[36].

Chapter 5 presents a control algorithm which allow the use of matrix converter in Direct Torque Control (DTC) for induction motor. The performance of this AC drive are analysed and discussed on the basis of numerical and experimental results. A modified control strategy that reduces the harmonic distortion of the input line current presented this year in a paper [37], is proposed.

## References

- [1] L. Gyugyi, B.R. Pelly, "Static Power Frequency Changers. Theory, performance and applications," ISBN 0-471-678000-7, 442 pages, John Wiley & Sons, USA, 1976.
- [2] N. Mohan, T.M. Undeland, W.P. Robbins, "Power Electronics. Converters, applications and design," ISBN 0-471-30576-6, 802 pages, 2<sup>nd</sup> Edition, John Wiley & Sons, USA 1995.
- [3] J.M.D. Murphy, F.G. Turnbull, "Power Electronic Control of AC Motors," Pergamon Press 1988, ISBN 0-08-022683-3, pages 524, 1988.
- [4] M. Venturini, "A new sine wave in, sine wave out, conversion technique eliminates reactive elements," in Proceedings of Powercon 7, San Diego,CA, 1980, pp. E3-1-E3-15.
- [5] A. Alesina, M. Venturini, "Solid-state power conversion: a Fourier analysis approach to generalized transformer synthesis," IEEE Transactions on Circuits System, vol. CAS-28, pp. 319-330, April 1981.
- [6] A. Alesina, M. Venturini, "Analysis and Design of Optimum-Amplitude Nine-Switch Direct AC-AC Converters", IEEE Transactions on Power Electronics, Vol. 4, no. 1, pp. 101-112, January 1989.
- [7] P.D. Ziogas, S.I. Khan, and M.H. Rashid, "Some Improved Forced Commutated Cycloconverters Structures", IEEE Transactions on Industry Applications, vol. IA-21, No 5, Sept./Oct. 1985, pp. 1242-1253.
- [8] A. Ishiguro, K. Inagaki, M. Ishida, S. Okuma, Y. Uchikawa, K. Iwata, "A new method of PWM control for forced commutated cycloconverters using microprocessors," Proceedings of IEEE/IAS Annual Meeting, 1988, pp. 712-721, 1988.
- [9] L. Huber, D. Borrojevic, "Space Vector Modulator for Forced Commutated Cycloconverter," Proceedings of IEEE/PESC'89, pp. 871-876, 1989.
- [10] C.L. Neft, C.D. Schauder, "Theory and Design of a 30-Hp Matrix Converter", Proceedings of IEEE/IAS Annual Meeting, 1988, pp. 934-939, 1988.
- [11] L. Huber, D. Borrojevic, "Space Vector Modulated Three-Phase to Three-Phase Matrix Converter with Input Power Factor Correction," IEEE Transactions on Industry Applications, Vol. 31, no. 6, pp.1234-1246, Nov./Dec. 1995.
- [12] D.G. Holmes, T.A. Lipo, "Implementation of a Controlled Rectifier Using AC-AC Matrix Converter Theory," IEEE Transactions on Power Electronics, Vol. 7, no. 1, pp.240-250, Jan. 1992.

- [13] D. Casadei, G. Grandi, G. Serra, A. Tani, "Space vector control of matrix converters with unity input power factor and sinusoidal input/output waveforms," Proceedings of IEE-EPE'93, Vol. 7, pp. 170-175, 1993.
- [14] Y. Kim, M. Ehsani, "Control of Force-Commutated Direct Frequency Changers," Proceedings of IEEE/IAS Annual Meeting, 1990, pp. 1163-1170, 1990.
- [15] E.P. Weichmann, J.R. Espinoza, L.D. Salazar, J.R. Rodriguez, "A Direct Frequency Converter Controlled by Space Vectors", Proceedings of IEEE/PESC'93, pp. 314-317, 1993.
- [16] R.R. Beasant, W.C. Beattie, A. Refsum, "An Approach to the Realisation of a High Power Venturini Converter", Proceedings of IEEE/PESC'90, pp. 291-297, 1990.
- [17] P.D. Ziogas, Y-G. Kang ,V. R. Stefanovic, "Rectifier-inverter frequency changers with suppressed DC link components," IEEE Transactions on Industry Applications, Vol. IA-22, No. 6, Nov./Dec. 1986, pp. 1027-1036.
- [18] S.I. Khan, P.D. Ziogas and M.H. Rashid, "Forced Commutated Cycloconverters for High-Frequency Link Applications", IEEE Transactions on Industry Applications, Vol. IA-23, No 4, July/August 1987, pp. 661-672.
- [19] A. Alesina, M. Venturini, "Intrinsic amplitude limits and optimum design of 9-switches direct PWM ac-ac converters," Proceedings of IEEE/PESC'88, vol. 2, pp. 1284-1291, 1988.
- [20] S. Bernet, T. Matsuo and T.A. Lipo, "A Matrix Converter Using Reverse Blocking NPT-IGBT's and Optimised Pulse Patterns," Proceedings of IEEE/PESC'96 , Baveno, Italy, June 1996, pp. 107-113.
- [21] P. Nielsen, F. Blaabjerg, J.K. Pedersen, "Space vector modulated matrix converter with minimised number of switchings and feedforward compensation of input voltage unbalance," Proceedings of PEDES'96, vol. 2, pp. 833-839, 1996.
- [22] P.W. Wheeler and D.A. Grant, "Optimised input filter design and low-loss switching techniques for a practical matrix converter," IEE Proceedings of Electric Power Applications, vol. 144, No. 1, pp. 53-60, Jan. 1997.
- [23] P. Nielsen, F. Blaabjerg, J.K. Pedersen, "Novel Solution for Protection of Matrix Converter to Three Phase Induction Machine," Conference Record of IEEE/IAS Annual Meeting 1997, New Orleans, pp. 1447-1454, 1997.

- [24] A.Schuster, "A Matrix Converter without Reactive Clamp Elements for an Induction Motor Drive System," Proceedings of IEEE/PESC'98, vol. 1, pp. 714-720,1998.
- [25] M. Ziegler, W. Hoffman, "Semi Natural Two Steps Commutation Strategy for Matrix Converters," Proceedings of IEEE/PESC'98, vol. 1, pp. 727-731, 1998.
- [26] L. Empringham, P.W. Wheeler, J.C. Clare, "Matrix Converter Bi-directional Switch Commutation using Intelligent Gate Drives," Proceedings of PEVD'98, pp. 626–631, 1998.
- [27] J. Mahlein, M. Braun, "A Matrix Converter without Diode clamped Over-Voltage Protection," Proceedings of IEEE-IPEMC 2000, Vol. 2, pp. 817-822, 2000.
- [28] C. Klumpner, P. Nielsen, I. Boldea, F. Blaabjerg, "New Steps towards a low-cost Power Electronic Building block for Matrix Converters," Proceedings of IEEE/IAS Annual Meeting 2000, vol. 3, pp. 1964-1971, 2000.
- [29] C. Klumpner, P. Nielsen, I. Boldea, F. Blaabjerg, "A New Matrix Converter-Motor (MCM) for Industry Applications," Proceedings of IEEE/IAS Annual Meeting 2000, vol. 3, pp. 1394-1402, 2000.
- [30] J. Chang, T. Sun, A. Wang, D. Braun, "Compact AC-AC Converter using 3-IN-1 IBPMs and Adaptive Commutation," IEEE Proceedings of PEDS'99, vol. 1, pp. 438-443, 1999.
- [31] M. Hornkamp, M. Loddenkotter, M. Munzer, O. Simon, M. Bruckmann, "Economac, the first all-in-one IGBT Module for Matrix Converter," PCIM 2001, Nurnberg.
- [32] B.K. Bose, "Power Electronics – A Technology Review," Proceedings of the IEEE, Vol. 80, No.8, August 1992, pp. 1303-1334, 1992.
- [33] J.D. Van Wyk, F.C. Lee, "Power Electronics Technology at the Dawn of the New Millenium – Status and Future," Proceedings of IEEE/PESC'99, Vol. 1, pp. 3-12, 1999.
- [34] K. Phillips, "Power Electronics: Will Our Current Technical Vision Take us to the Next Level of AC Drive Product Performance?," Proceedings of the IEEE/IAS Annual Meeting 2000, CD-ROM, paper 1.1, pp. 1-9, 2000.
- [35] P. Thøgersen, F. Blaabjerg, "Adjustable speed drives in the next decade. The next step in industry and academia," Proceedings of PCIM'00, Intelligent Motion, pp. 95-104, 2000.
- [36] R.D. Lorenz, "The Future of Electric Drives: Where are we headed?," Proceedings of PEVD'00, pp. 1-6, 2000.

- [37] F. Blaabjerg, D. Casadei, C. Klumpner, M. Matteini, "Comparison of two current modulation strategies for matrix converters under unbalanced input voltage conditions," Proceedings of IEEE/ISIE 2000, Vol. 2, pp. 465-470, 2000.
- [38] D. Casadei, C. Klumpner, M. Matteini, G. Serra, A. Tani, "Input power quality in matrix converters: minimization of the RMS value of input current disturbances under unbalanced and nonsinusoidal supply voltages," Proceedings of IEEE/NORPIE/2000, pp. 129-133, 2000.
- [39] F. Blaabjerg, D. Casadei, M. Matteini, G. Serra, A. Tani, "Direct Torque Control using Matrix Converters: Improvement of the Input Line Current Quality," Proceedings of EPE 2001, CD-ROM, paper 000949, pp. 1-10, 2001.
- [40] M. Bramouille, "Electrolytic of films capacitors?", Proceedings of IEEE/IAS Annual Meeting, paper 25.3, CD ROM, pp. 1138-1141, 1998.
- [41] Hitachi Inverter – J100 SERIES, Instruction manual, Appendix 5, pp. A-19, Hitachi Ltd., Tokyo, Japan.