

Power Quality and Reliability Supply Improvement Using a Power Conditioning System with Energy Storage Capability

D. Casadei, Member, IEEE, G. Grandi, Member, IEEE, C. Rossi

Department of Electrical Engineering, University of Bologna, via Risorgimento, 2 I-40136 Bologna ITALY, email: domenico.casadei@mail.ing.unibo.it, gabriele.grandi@mail.ing.unibo.it, claudio.rossi@mail.ing.unibo.it

Abstract-- A power conditioning system with energy storage capability is proposed as a viable solution for improving the quality and the reliability of the electric energy supply. Several tasks can be performed at the same time, such as reactive power compensation, current harmonic reduction, and smoothing of pulsating loads. Moreover, the power conditioning system can operate as an uninterruptible power supply during short time interruptions of the grid supply. The proposed system is a flexible structure that can be coupled to several energy storage devices like batteries, flywheels, supercapacitors, superconductive magnetic energy storage systems. In order to show the power conditioning system performance, experimental tests have been carried out using a flywheel as storage device. The effectiveness of the proposed control system has been successfully verified in several operating conditions of the grid supply and of the load.

Index Terms-- Uninterruptible power systems, Power conditioning, Energy Storage, Flywheels, Supercapacitors, Power quality.

I. INTRODUCTION

In practical applications a high reliability power supply is required for critical loads. In general, this requirement is fulfilled by a standard UPS configuration based on the series connection of a Voltage Source Inverter (VSI) between the grid and the load. The energy is usually stored in a lead acid battery bank. It can be noted that, about 90% of grid faults are very short (less of 1s), and in the remaining cases the UPS supplies the load for the time interval required for starting up a diesel or turbine generator set. In these cases the UPS supplies the load for no more than 30 seconds. As a consequence, for these high power and low energy applications the lead acid battery bank is often oversized, and an extra cost is paid for an energy reserve that will never be used.

The research activities in the field of high power - low energy batteries, in particular for hybrid electric vehicles, is aimed to the development of new kinds of batteries. Spiral wound lead acid batteries and nickel-metal hydride batteries have increased power performance with respect to standard lead acid batteries, but it is not yet satisfactory for application where the whole stored energy must be supplied in less than one minute [1].

Using new types of energy storage devices, such as superconducting magnets, flywheels or supercapacitors, which are more suitable for high power and low energy applications, it is possible to better exploit the energy reserve [2].

These new storage devices allow additional tasks to be performed using the same hardware structure required for the UPS operation. The additional tasks consist of reactive power compensation, current harmonic reduction, load unbalance compensation, and smoothing of pulsating loads. In this way, the UPS behaves as a Power Conditioning System (PCS) when the grid supply is present, improving signifi-

cantly the power quality in the grid section next to the Point of Common Coupling (PCC) [3].

Such a power conditioning system requires a storage device that is able to charge and discharge in a time between few seconds and one minute. The power rating varies from 10 kW to 1 MW, while the stored energy is comprised between 1 and 10 MJ.

Flywheels and supercapacitors are designed for a variety of applications beyond power quality, in particular in space (satellite, space station) and in hybrid vehicle (bus, car, combat vehicle) coupled with internal combustion engines or fuel cells. A growing number of applications based on flywheel and supercapacitors is reported each year.

Nowadays, Superconducting Magnet Energy Storage (SMES) represents a research field where very few applications are reported. Promising research projects about SMES have been carried out in order to utilize this energy storage system for electromagnetic aircraft launchers on aircraft carrier ships.

Modern flywheels [4-5] are based on rotor made of steel or carbon fiber, rotating at speed between 10,000 and 60,000 rpm, with rim speed from 0.5 to 1 km/s. Rotor is often directly coupled to a Permanent Magnet Synchronous Machines (PMSM) operating both as motor and generator. Rotor is always inserted in an explosion proof case, which, for the highest speed devices, keeps the rotor under vacuum. Flywheels operate equally well on frequent light discharges and on very deep discharge. The state of charge of a flywheel is directly determined from its rotational speed. Peak power is limited by the rating of the electrical machines and of the power electronic converter.

Supercapacitors are new electrochemical storage devices based on the principle of the double layer - electrolyte capacity [6]. Organic electrolyte and activated carbon electrodes represent the most promising and mature technologies for the success of supercapacitors. A typical commercial cell has a maximum operating voltage of 2.3 V, a capacity of about 2500 F, in a volume of less than 0.5 dm³. To obtain higher voltages, it is necessary to connect in series a high number of cells. In a bank of series connected supercapacitor, cells have dispersed value of capacity, so it is often used an electronic cell-balancing system that take under control the voltage across each cell preventing it overcome the maximum operating voltage value. The state of charge of a supercapacitor bank can be easily determined by measuring the voltage across the bank. Peak power is mainly limited by Joule losses in the internal series resistance of the supercapacitors.

The SMES system stores energy in a magnetic field generated by a coil of superconductive wire. The superconductive wire exhibits zero resistivity at cryogenic temperature (e.g., NbTi wire become superconductive at 4.2K). It means that a current circulating in such a coil can persist for a long time without losses. However, keeping the coil at

Table I - Comparison of storage device system for PCS application

Storage device	peak power [W/kg]	power 60" [W/kg]	life [number of deep discharges]	cost [€/kW ^{60"}]	availability
Advanced battery	600	100	<300	50-100	commercial
Flywheel	300	130	>100.000	400-800	prototypes
Supercapacitor bank	3500	250	>10.000	100-120	pre-industrial

cryogenic temperature, by using cryocooler or liquid helium requires energy. Main research activities are targeted to develop materials for the coil wire, that are superconductive at the temperature of the liquid nitrogen (77,36 °K) [7]. The level of current circulating in the coil determines directly the state of charge of a SMES. Size of SMES are mainly limited by the high level of generated magnetic field. Peak power is limited by Joule losses in non-superconductive terminals of the SMES and by the current rating of the power electronic converter connected to the SMES.

Table I compares data of these new storage device systems with the lead acid batteries. Reference is made to the case in which the whole stored energy must be supplied in 60 seconds.

From table I it is clear that supercapacitor are the best choice as energy storage system when the energy request is represented by frequent and short charge - discharge cycles (flicker compensation) and deep discharge in less than 60" (UPS operation).

This paper presents a control structure of the Power Conditioning System that can be utilize with any of the presented new Storage Devices: SMES, Flywheel, and Supercapacitor.

II. SYSTEM DESCRIPTION

The basic scheme and control system of the proposed PCS is shown in Fig. 1. The energy Storage Device (SD) is connected to a static converter, which allows the bi-directional energy flow with the dc-link bus. The topology of this converter depends on the type of the energy storage device. The supercapacitor bank needs a boost converter capable to control the level of voltage across the terminal of supercapacitor [8]. The SMES needs a two-quadrant converter capable to control the level of the current flowing into the coil [9]. The machine connected to the flywheel is driven by a three-phase inverter controlled by a vector control technique.

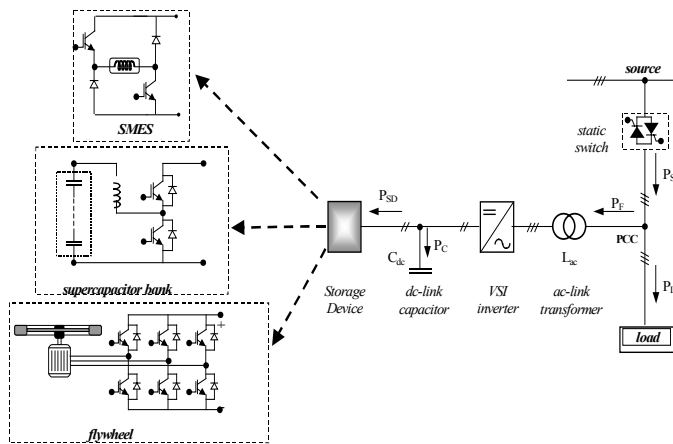

Fig. 1. Schematic drawing of the PCS structure

At the same intermediate dc-link is connected a three-phase Voltage Source Inverter (VSI) with the output connected to the mains in the Point of Common Coupling (PCC) through three coupling inductors. The PCC is supplied by the mains through a static switch that is switched on during the operation of the system as power conditioner and that must be turned off during the operation of the system as supply voltage back-up.

When the grid supply is present, the stored energy can be used to compensate flicker phenomena due to sudden and repetitive load changes. During these transients the PCS exchanges a given quantity of the stored energy in order to deliver the difference between the instantaneous load power and its average value, which is supplied by the source.

Fig. 1 shows that the dc/ac section of the PCS connected to the mains has the same topology of a shunt active power filter [11]. Then, by means of a suitable control of the PCS it is also possible to compensate the load reactive power, to reduce the current harmonics of non linear loads, and to compensate unbalanced loads. These features are achieved by the direct control of the currents through the ac-link inductors in order to force the source currents to be balanced and sinusoidal for any operating condition. The source currents are synchronized with the fundamental positive sequence component of the source voltages. As a consequence, balanced and sinusoidal source currents with unity power factor can be obtained, even in presence of voltage perturbations coming from the mains [10].

In the case of a power outage, the PCS changes its operating mode and behaves as a voltage source, by using the energy stored in the SD to supply the load.

The control structure of the PCS is splitted on two levels. The higher level, called Energy Control System (ECS), is the regulating structure that, on the basis of the operating conditions, generates the reference for power flows among the sections of the PCS. The proposed ECS is the same for anyone of the described storage devices.

The lower level is constituted by the regulating structure that controls the two converters in order to follow the power references given by the higher level control system. The control of the converter connected to the storage device depends on the SD type.

A power conditioning system having all the described features has been realized in laboratory, according to the scheme represented in Fig. 1. The performance of the PCS has been verified by experimental tests and good results have been achieved both in active power filter operation and UPS operation.

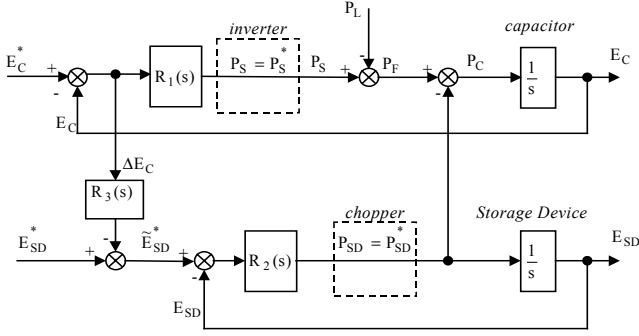

Fig. 2. Block diagram of the Energy Control System

III. ANALYSIS OF THE ENERGY CONTROL SYSTEM

When the supply grid is present, the flicker phenomena compensation and the active filter operation are achieved operating the PCS in "current source mode". When a failure of the mains is detected, the control system commutates the operating status from "current source mode" to "voltage source mode" and the PCS behaves as UPS.

A commutation strategy based on the monitoring of the source voltage vector \bar{e}_s allows the commutation between the two control modes, with a reduced discontinuity in the voltage applied to the load.

A. Current Source Mode

During the operation of the PCS as current source, the energy transfer among the storage device, the dc-link capacitor and the ac network is performed by the energy control system. The analysis of the ECS can be usefully carried out in terms of power flows and energy balance [11].

The combined operation of the PCS as active filter and flicker smoother is achieved by a suitable control algorithm, that manages the energy transfer among the energy storage device, the dc-link capacitor, and the mains.

The analysis of the ECS is based on the following assumptions:

- the low level control structure is able to keep the source power P_S , and the storage device power P_{SD} close to their references, i.e. P_S^* and P_{SD}^* ;
- losses in passive components such as inductors, capacitors, storage device, and in the static switches are neglected.

These two assumptions are acceptable because of the low time response of the low level control structure used to drive the two converters and the small amount of the losses in the passive components. Furthermore, the dynamic response of the storage device to a power demand must be fast enough to allow the tracking of the energy variations demanded by the ECS.

In order to explain the principle of operation of the ECS, reference is made to a load power perturbation. Any load power change determines a variation of the power supplied by the PCS and then a variation of the energy stored in the dc link capacitor. This energy should be quickly restored to its reference value using energy coming from the storage device. As a consequence, a power flow is established between the PCS and the point of common coupling. In this

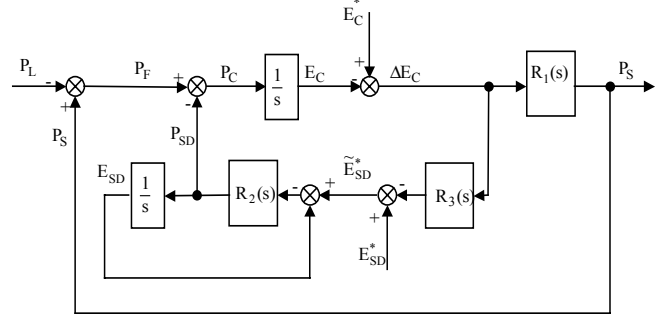

Fig. 3. Block diagram showing the relationship between P_L and P_S

way at a switching-on of the load, the source is not required to supply instantaneously the full load power, but only an increasing percentage, being the remaining amount of power supplied by the PCS. During this transient the energy supplied by the PCS can be considered as coming directly from the SD unit. The use of the SD unit for smoothing load variations is necessary because the dc link capacitor has very low stored energy, and only small dc-link voltage variations can be allowed to ensure a correct operation of the grid inverter.

The behavior of the ECS can be analyzed in terms of Laplace transform, in according to the control scheme shown in Fig. 2, where the input control variables are the energy in the dc-link capacitor E_C^* , and the energy in the storage device E_{SD}^* . The regulator R_1 generates the reference source power P_S^* , on the basis of the dc-link capacitor energy error. The inverter power, P_F , that should be exchanged from the mains to the inverter is obtained by subtracting the load power to the source power, $P_F = P_S - P_L$. The regulator R_3 varies the reference value of the SD energy on the basis of the error in the dc-link capacitor energy. R_2 acts to keep the SD energy close to its reference value by exchanging power with the dc-link.

Analyzing the transfer function of the control scheme given in Fig. 3, it is possible to emphasize the PCS behaviour in response to variation of the load power. The control scheme of Fig. 3 has been derived rearranging the basic scheme of Fig. 2, by considering the load power P_L as input signal, and the source power P_S as output variable. The references for the dc-link capacitor energy and for the SD energy can be considered as disturbances having a constant value. In this way, the relationship between the source power and the load power is determined as the sum of three terms, as follows

$$P_S(s) = G_C(s)E_C^* + G_{SD}(s)E_{SD}^* + G_L(s)P_L. \quad (1)$$

Assuming for the regulators of Fig. 3 the following expressions:

- capacitor energy regulator: $R_1(s) = K_{p1} + \frac{K_{i1}}{s}$,
- storage device energy regulator: $R_2(s) = K_{p2}$,
- SD energy reference regulator: $R_3(s) = K_{p3}$,

the expression of $G_C(s)$, $G_{SD}(s)$, $G_L(s)$ are

$$G_C(s) = \frac{K_{p1}s^3 + (K_{p1}K_{p2} + K_{i1})s^2 + K_{p1}K_{p2}s}{s^3 + (K_{p1} + K_{p2} + K_{p3}K_{p2})s^2 + (K_{i1} + K_{p1}K_{p2})s + K_{p1}K_{p2}}, \quad (2)$$

$$G_{SD}(s) = \frac{K_{P1}K_{P2}s^2 + K_{P1}K_{P2}s}{s^3 + (K_{P1} + K_{P2} + K_{P3}K_{P2})s^2 + (K_{I1} + K_{P1}K_{P2})s + K_{I1}K_{P2}}, \quad (3)$$

$$G_L(s) = \frac{K_{P1}s^2 + (K_{P1}K_{P2} + K_{I1})s + K_{I1}K_{P2}}{s^3 + (K_{P1} + K_{P3}K_{P2})s^2 + (K_{I1} + K_{P1}K_{P2})s + K_{I1}K_{P2}}. \quad (4)$$

Under the assumption that E_C^* and E_{SD}^* are constant, $G_C(s)$ and $G_{SD}(s)$, do not introduce steady state error on P_S and the transfer function that represents the behaviour of the source power P_S in response to load power P_L variations, from (1), becomes $P_S(s) = G_L(s)P_L(s)$.

The need of a fast response of the SD energy regulator requires a larger value for K_{P2} , ($K_{P2} \gg K_{P1}$, K_{I1} , K_{P3}), this assumption allows to simplify (4) yielding to the following typical second order transfer function

$$\hat{G}_L(s) = \frac{\omega_n^2(1 + Ts)}{s^2 + 2\delta\omega_n s + \omega_n^2}, \quad (5)$$

where the parameter K_{P2} does not affect the transfer function and the value of the damping factor δ , natural frequency ω_n and time constant T are respectively:

$$\omega_n = \sqrt{\frac{K_{I1}}{K_{P3}}}, \quad \delta = \frac{1}{2} \frac{K_{P1}}{\sqrt{K_{I1}K_{P3}}}, \quad T = \frac{2\delta}{\omega_n} = \frac{K_{I1}}{K_{P3}}.$$

A design criteria that allows to set the parameters of the three regulators of the ECS can be synthesized as follows.

The parameter K_{P3} of the SD energy reference regulator must be chosen on the basis of the energy availability in the two storage devices: dc-link capacitor and storage device. It defines directly the SD energy reference variation from the variation of the energy in the dc-link capacitor. A value that can be conveniently used to determine the same relative energy variation in the two storage devices is $K_{P3} = E_{SD}^*/E_C^*$.

Once K_{P3} is chosen, the two parameters of the regulator $R_1(s)$ can be determined on the basis of desired time response of the source power due to a load power step. From the chosen value of δ , ω_n the parameter K_{P1} and K_{I1} of $R_1(s)$ can be easily determined as

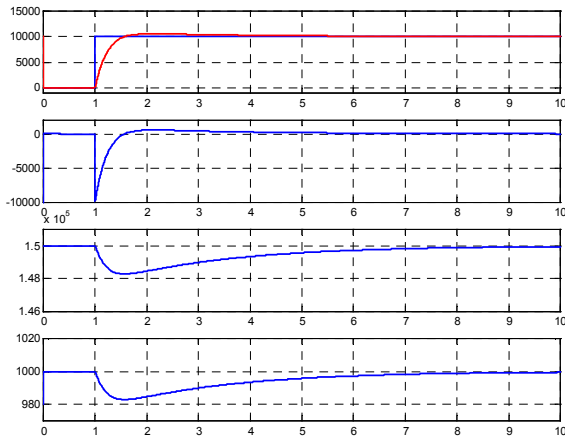

Fig. 4. Step response to a load switching on. From the top to bottom: a) source and load instantaneous power P_S , P_L ; b) Storage device power P_{SD} ; c) Storage device energy E_{SD} ; d) dc-link capacitor energy E_C .

dc capacitor energy reference	E_C^*	1000 [J]
load power	P_L	10 [kW]
SD energy reference	E_{SD}^*	150 [kJ]
$R_1(s)$	K_{P1}	500
	K_{I1}	200
$R_2(s)$	K_{P2}	1000
$R_3(s)$	K_{P3}	100

$$\begin{cases} K_{P1} = 2\delta\omega_n\sqrt{K_{P3}} \\ K_{I1} = \omega_n^2 K_{P3} \end{cases} \quad (6)$$

A large value of K_{P2} , $K_{P2} \gg 1$, must be chosen such the proper operation of the SD energy regulator is guaranteed.

The performance of a PCS characterized by the data given in Tab. II has been numerically analysed by using the relationship (1). The results of this analysis are shown in Figs. 4 and 5.

The SD energy is high enough to supply the load during short blackouts of the mains. As a consequence, during the operation of the system as power conditioner, the energy variations in the storage device are very small.

B. Voltage source mode

During grid faults, the operation of the PCS as voltage source is obtained by a simple control system, which allows the supplying of the load using the energy stored in the SD. The block diagram of the ECS employed in the ‘‘voltage source mode’’ is shown in Fig. 6. In this control system the power flow coming from the SD is directly transferred to the load, by keeping the voltage (energy) in the intermediate dc-link bus at a given level.

The regulator $R(s)$ acts on the error of the dc-link capacitor energy, generating the power demand P_{SD}^* from the storage device. Assuming that the SD converter is able to extract this power from the SD, the dc-link capacitor receives from the SD the same amount of power that is supplied to the load through the inverter.

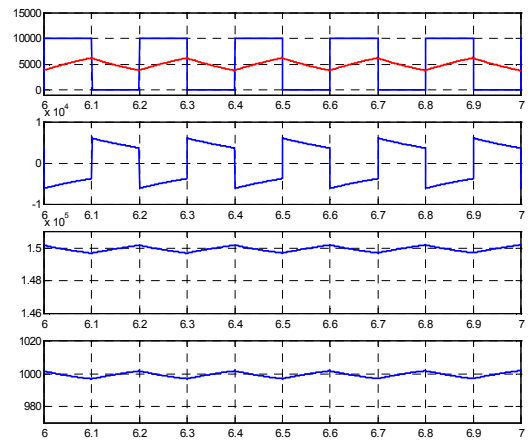

Fig. 5. Response of the PCS to a pulsating load. From the top to bottom: a) source and load instantaneous power P_S , P_L ; b) Storage device power P_{SD} ; c) Storage device energy E_{SD} ; d) dc-link capacitor energy E_C .

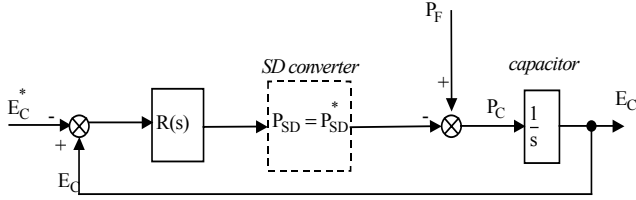

Fig. 6. Block diagram of the Energy Control System used in the “voltage source mode”.

IV. IMPLEMENTATION OF THE CONTROL SYSTEM

The energy control system required for operating the PCS in the “current source mode” has been implemented introducing some practical simplifications with respect to the basic scheme of Fig. 2.

The energy level in the dc-link capacitor is kept under control using the capacitor voltage V_C as control variable. The source power is regulated using the source current \bar{i}_S as control variable. Figs. 7 and 8 show the control system modified according to these considerations.

The reference source current \bar{i}_S^* is obtained by multiplying the unity vector \hat{v}_S^{+1} , by the reference source current magnitude I_S^* , where:

- the unity vector \hat{v}_S^{+1} is in phase with the positive sequence fundamental component of the line to neutral voltage \hat{v}_S , and it is generated by a three phase locked loop algorithm. This algorithm operates correctly even in the case of unbalanced and non sinusoidal voltages;
- the reference source current magnitude I_S^* is generated by the regulator $R_1(s)$, which operates on the instantaneous error between the reference value V_C^* and the actual value V_C of the dc-link voltage.

The ac current regulator synthesizes the reference source current. This regulator operates in order to keep the source current \bar{i}_S close to its reference value \bar{i}_S^* .

The regulator $R_2(s)$ of the energy control system controls the energy level in the storage device. This goal has been achieved controlling the voltage across the supercapacitors, or the rotating speed of the flywheel. This regulation is performed by the converter between the dc-link and the storage device.

The commutation between “current source mode” and “voltage source mode” is performed by a supervisor algorithm. When the grid is present, the supervisor algorithm calculates the instantaneous value of the source voltage vector \bar{v}_S by monitoring the source voltages. Assuming

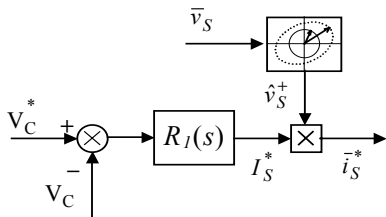

Fig. 7. Dc-link voltage controller

balanced and sinusoidal supply voltages, the voltage vector \bar{v}_S rotates at constant speed describing a circular locus. In case of unbalanced or non sinusoidal supply voltages, the trajectory described by the voltage vector \bar{v}_S deviates from a circle, causing variations of the magnitude and angular velocity. Perturbation of the supply voltages, such as voltage sags, large voltage drops, zero voltage conditions, cause large deviations of the voltage vector trajectory. A critical circular region has been defined in order to detect these perturbations and to start the commutation sequence. If the voltage vector lays in the critical region for a time interval greater than a given value, the supervisor algorithm disables the “current source mode”, drives the opening of the static switch, and when the source currents are almost zero, enables the operation of the PCS in “voltage source mode”. During the commutation sequence, the phase angle of the source voltage is estimated allowing the PCS to supply the load with a reduced voltage discontinuity. During the operation of the PCS in “voltage source mode”, the grid voltage is continuously monitored and when the source voltage vector leaves the critical region permanently, the control system commutates from the “voltage source mode” to the “current source mode”. During this commutation a PLL algorithm allows to synchronize the voltage vector applied to the load with the restored source voltage. In this way, the commutation is obtained without discontinuities on the voltage applied to the load.

V. EXPERIMENTAL RESULTS

A 30 kVA system prototype has been realized with the characteristics reported in Tab. III. A flywheel driven by an induction machine has been used as energy storage device. The system configuration is the same as in Fig. 1, therefore the PCS is able to compensate flicker phenomena, to behave as active power filter, and to ensure the continuity of the load supply during short time interruption of the grid.

The control system has been implemented on a PPC 333 MHz DSP. Fig. 9 and 10 shows the capability of the PCS to operate in current source mode. In fig. 9 the system behaves as active filter compensating the reactive power due to a R-L linear load. Fig. 10 shows the transient response caused by a load pulsating at a frequency of 1 Hz, with a duty cycle of 10%. The effect of the PCS is to keep the source current amplitude almost constant and equals to the mean value of the load current. This is achieved exchanging a fraction of the energy stored in the flywheel with the load. Fig. 11 shows the behaviour of the system during a short interruption of the source supply. During this transient the system commutates its operating mode from current source mode to voltage source mode, then it supplies the load during the grid fault by employing the mechanical energy stored in the

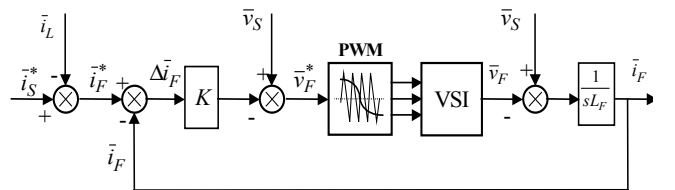

Fig. 8. Ac current controller

Table III - Main data of the PCS prototype

utility voltage	V_S	220 [V]
utility frequency	f_S	50 [Hz]
3 phase ac-link inductor	L_{ac}	2 [mH]
static switch	TRIACS (3x)	
dc-link capacitance	C_C	10 [mF]
flywheel inertia	J_{SD}	0.3 [kg.m ²]
reference value of dc-link voltage	V_C^*	450 [V]
reference value of flywheel speed	n_{SD}^*	3000 [rpm]

flywheel, which decreases its rotating speed. At the end of the power outage the system commutates again its operating mode from voltage mode to current mode, then the level of energy stored in the flywheel is increased by using power coming from the grid. After few second of recharging operation the rotating speed of the flywheel is restored to its reference value.

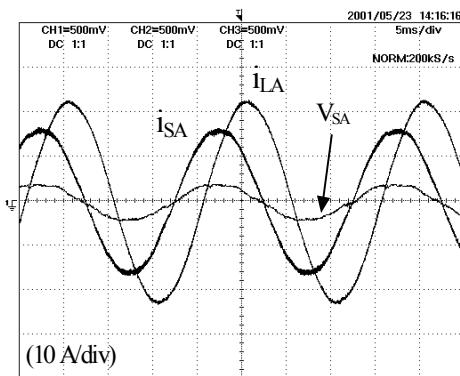

Fig. 9. Compensation of load reactive power

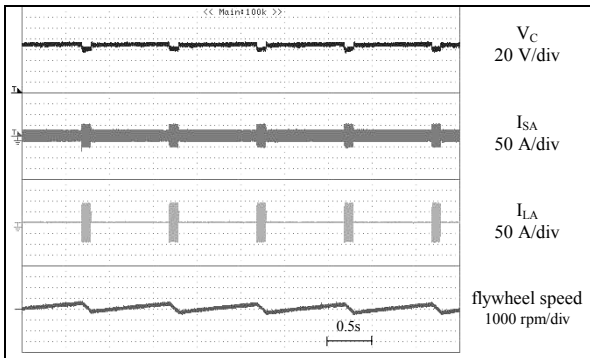

Fig. 10. Response of the PCS to a pulsating load

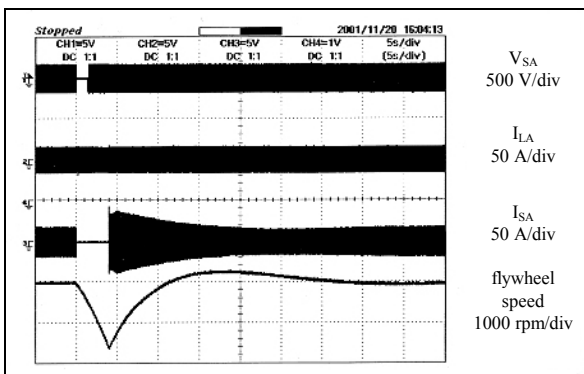

Fig. 11. Short interruption of the source supply

VI. CONCLUSION

The performance of a PCS with the capability to meet several power quality requirements has been analysed and verified by experimental tests. An analytical approach has been used to determine the parameters of the three regulators. A PCS prototype with a rated power of 30 kVA has been realized in laboratory. Tests have been carried out in different operating conditions. It has been verified that this system is able to compensate reactive power and current harmonics due to non-linear loads. Furthermore, the results obtained have shown that the presence of an energy storage device makes it possible to reduce the source current variations due to pulsating loads, and to ensure the continuity of the supply during brief outage. The experimental results are quite satisfactory, showing the effectiveness of the proposed control scheme in improving the power quality and the reliability of the power supply.

VII. REFERENCES

1. J. McDowall, "Conventional battery technologies—Present and future," in Proc. IEEE Power Engineering Society Summer Meeting, vol. 3, July 2000, pp. 1538–1540.
2. P.F. Ribeiro, B.K. Johnson, M.L. Crow, A. Arsoy, Y. Liu, "Energy storage systems for advanced power applications," Proc. of the IEEE, Vol. 89 Issue: 12, Dec. 2001 Page(s): 1744 -1756
3. H. Akagi, "Active filters and energy storage systems operated under non-periodic conditions" Proc. of Power Engineering Society Summer Meeting, 2000. IEEE, 16-20 July 2000 Page(s): 965 - 970 vol. 2
4. R. Hebner, J. Beno, A. Walls, "Flywheel batteries come around again" Spectrum, IEEE, Volume: 39 Issue: 4, April 2002 Page(s): 46 -51
5. J.D. Boyes, N.H. Clark "Technologies for energy storage. Flywheels and super conducting magnetic energy storage Power Engineering" Proc. of Society Summer Meeting, 2000. IEEE, 16-20 July 2000 Page(s): 1548 -1550 vol. 3
6. P. P. Barker, "Ultracapacitors for use in power quality and distributed resource applications" Proc. of Power Engineering Society Summer Meeting, 2002 IEEE, 21-25 July 2002 Page(s): 316 -320 vol.1
7. M. Fabbri, F. Negrini, P.L. Ribani, "Optimized Magnetic Design of a High Temperature micro-SMES", Int. J. of Modern Physics B, vol. 13, n. 9 & 10, pp. 1351-1356, 1999.
8. B.J. Arnet, L.P. Haines, "High power DC-to-DC converter for supercapacitors" Proc. of IEEE Electric Machines and Drives Conference, 2001. IEMDC 2001, pp. 985 -990
9. P. Zhu, X. Kong, H. Zhang, C. Han, Y. Kang, J. Chen, "The power conversion system performance of a superconducting magnetic energy storage unit" Proc. of 4th IEEE Power Electronics and Drive Systems Conference, Vol.2, 22-25 Oct. 2001, pp. 611 -617
10. D. Casadei, G. Grandi, C. Rossi: "Effects of Supply Voltage non-Idealities on the Behavior of an Active Power Conditioner for Co-generation Systems", IEEE Power Electronics Specialists Conference, IEEE-PESC, Galway, Ireland, 18-23 June, 2000
11. D. Casadei, G. Grandi, C. Rossi: "A Parallel Power Conditioning System with Energy Storage Capability for Power Quality Improvement in Industrial Plants", EPE, Graz, Austria, 27-29 August, 2001